



12.8V200Ah Lithium Battery

Datasheet, Version 123



Features:

- 200Ah
- Built in protections
- Maintenance-free
- LiFePO4 technology



12.8V200Ah Lithium Battery

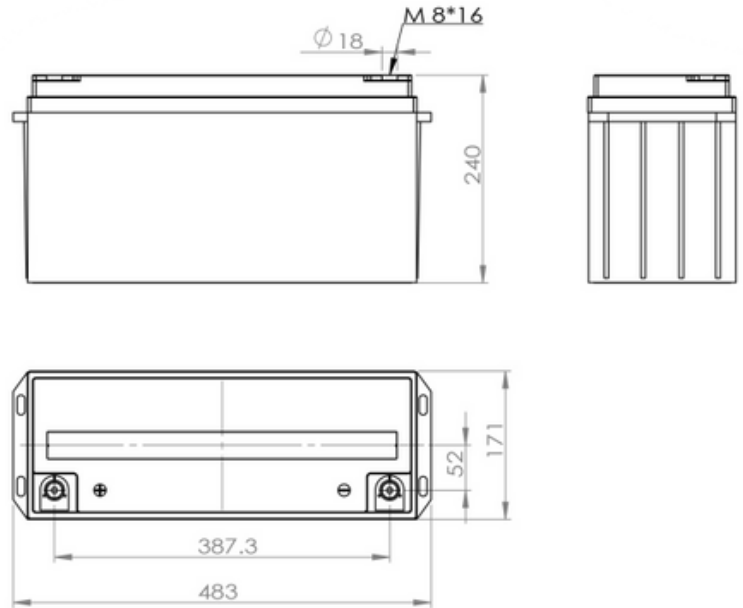

Features of LiFePO4 Battery

- » The whole module is non-toxic, non-polluting and environmentally friendly;
- » Cathode material is made from LiFePO4 with safety performance and long cycle life;
- » Battery management system(BMS) has protection functions including over-discharge, over-charge, over-current and high/low temperature;
- » Small size and light weight, comfortable for installation and maintenance

Application

- » Wheelchairs and scooters;
- » Solar/wind energy storage;
- » Back-up power for small UPS;
- » Golf trolleys & buggies



12.8V200Ah Lithium Battery

Electrical Characteristics	Nominal Voltage	12.8V
	Combination method	200Ah
	Energy	2560WH
	Internal Resistance (AC)	≤20mΩ
	Cycle Life	>4500 cycles @0.5C 80%DOD
	Months self Discharge	<3%
	Efficiency of Charge	100%@0.5C
	Efficiency of discharge	96-99% @0.5C
Standard Charge	Charge Voltage	14.6±0.2V
	Charge Mode	0.5C to 14.6V, then 14.6V,charge current to 0.02C(CC/cV)
	Charge Current	80A
	Max.Charge Current	100A
	Charge Cut-off Voltage	14.6±0.2V
Standard Discharge	Continuous Current	100A
	Max.Pulse Current	200A(<3S)
	Discharge Cut-off Voltage	10V
Environmental	Charge Temperature	0 °C to 55 °C (32F to 131F)@60±25% Relative Humidity
	Discharge Temperature	-20 °C to 60 °C (-4F to 140F)@60±25% Relative Humidity
	Storage Temperature	-20 °C to 45 °C (-4F to 113F)@60±25% Relative Humidity
	IP Class	IP66
Mechanical	Plastic Case	ABS
	Approx. Dimensions	531*207*226mm
	Approx.Weight	24.0kgs
	Terminal	M8

Performance characteristics

Discharge rate curves

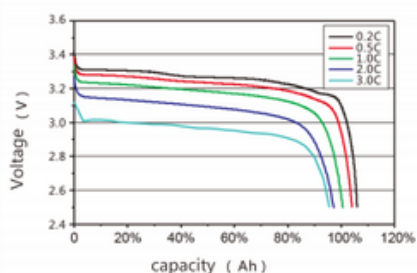

Temperature Characteristics

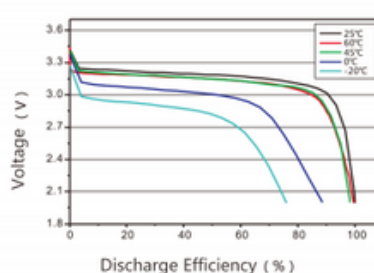

Cycle curves of 4500 times

